

4.9-5.9 GHz 3W Power Amplifier Module

August 2009 - Rev 30-Aug-09

Features

- ✕ P1dB, 34.5 dBm
- ✕ Pout 26 dBm @ EVM = 2.5% (PAR=9.17 dB)
- ✕ OIP3, 46 dBm
- ✕ Gain, 17 dB
- ✕ Voltage, 8V
- ✕ Input Internally Matched
- ✕ 7X7mm Surface Mount Package
- ✕ Ideal for WiMAX Applications @ 5.8GHz

General Description

The XP1044-QL is a highly linear 2-stage power amplifier capable of 17 dB of gain, 3W of power at 1 dB compression and is housed in an RoHS compliant 7X7mm package. The XP1044-QL provides less than 2.5% EVM at 26 dBm output power with 802.16 OFDM signal and peak to average ratio 9.17 dB. The input and output of the device are internally pre-matched facilitating a simplified input and output match. This product operates off an 8V voltage supply and requires negative voltage which is used for current control. XP1044-QL is specifically designed for WiMAX applications between 4.9 GHz and 5.9 GHz.

Functional Block Diagram

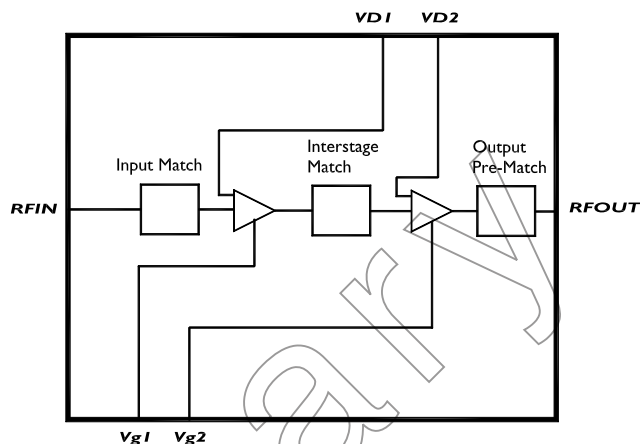

Absolute Maximum Ratings

Supply Voltage	+9.0V
RF Input Power ¹	+23 dBm
Storage Temperature	-55 to +125 °C
Junctions Temperature	175 °C
Operating Temperature	-40 to See Note 1
Thermal Resistance (Rth)*	20 °C/W

* Thermal resistance of stage 2

(1) Calculate maximum operating backside temperature using the following formula: $T_{max} = 175^{\circ}\text{C} - [V_{cc} * I_{dd2} * R_{th}]$

Electrical Characteristics (T=25 °C, Voltage Supply=8V)

Unless otherwise specified, the following specifications are guaranteed at room temperature in a Mimix test fixture.

Parameter	Units	Min.	Typ.	Max.
Frequency Range (f)	GHz	4.9	5.8	5.9
Power Gain (@ Pout=27 dBm)	dB	15	17.0	
Linear Power (@ EVM=2.5%, OFDM, 802.16 PAR=9 dB)	dBm		26.0	
Input Return Loss (S11)	dB	-10.0		
Output IP3 @ 22 dBm/Tone	dBm	44.0	46.0	
Noise Figure	dB		5	
Output P1dB	dBm		34.5	
Stage 1 Current (Idd1)	mA		450	
State 2 Current (Idd2)	mA		600	
Stage 1 Gate Voltage (Vg1)	V		-1.3	
Stage 2 Gate Voltage (Vg2)	V		-1.0	
Supply Voltage	V	5.0	8.0	

4.9-5.9 GHz 3W Power Amplifier Module

August 2009 - Rev 30-Aug-09

PI044-QL
RoHS

Typical Performance

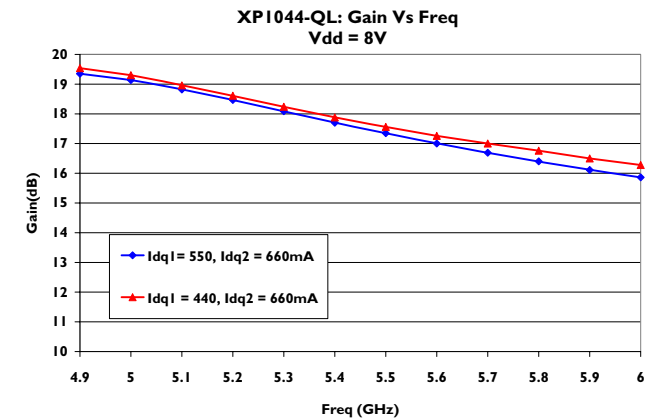
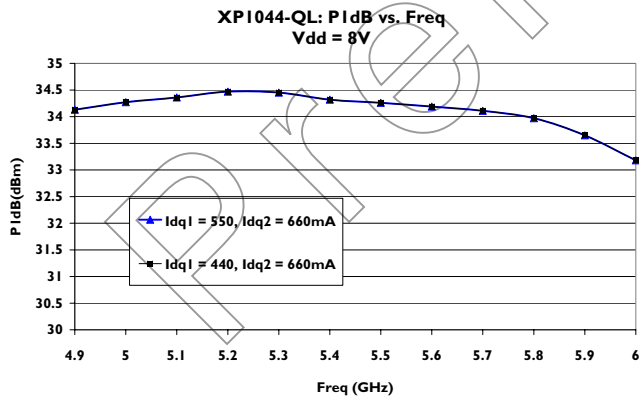
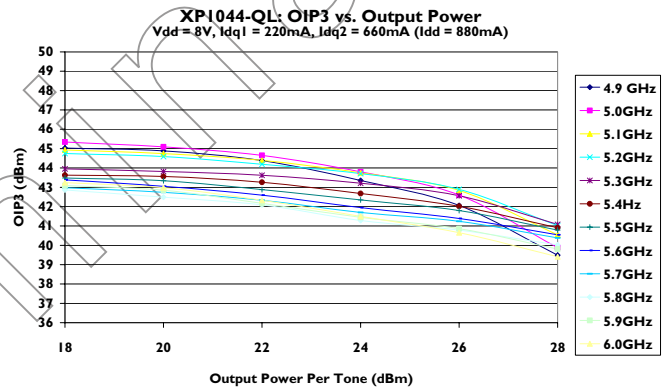
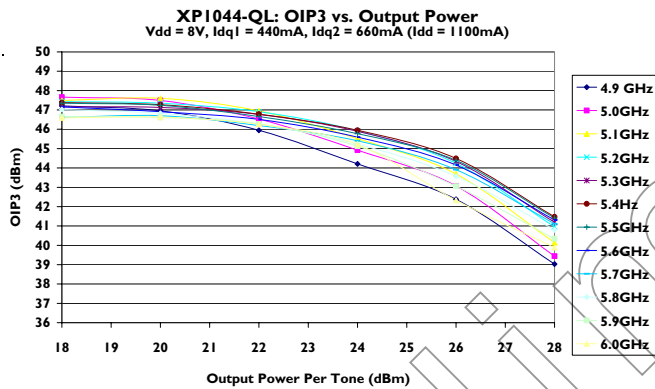
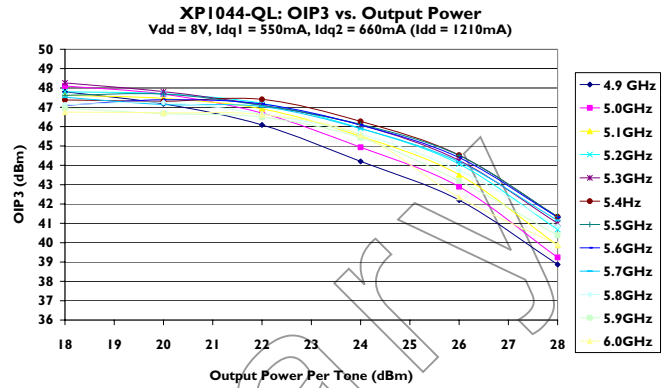
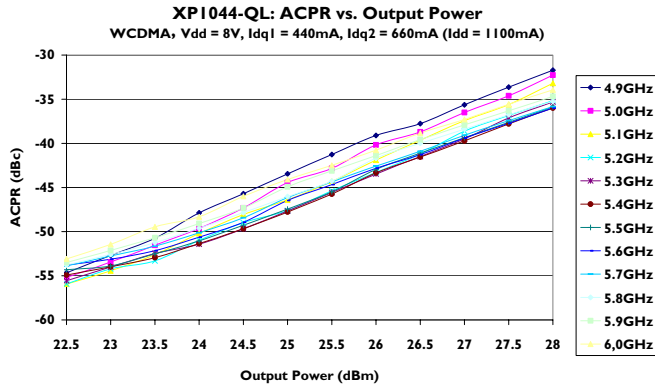

4.9-5.9 GHz 3W Power Amplifier Module

August 2009 - Rev 30-Aug-09

PI044-QL
RoHS

Pin Assignment

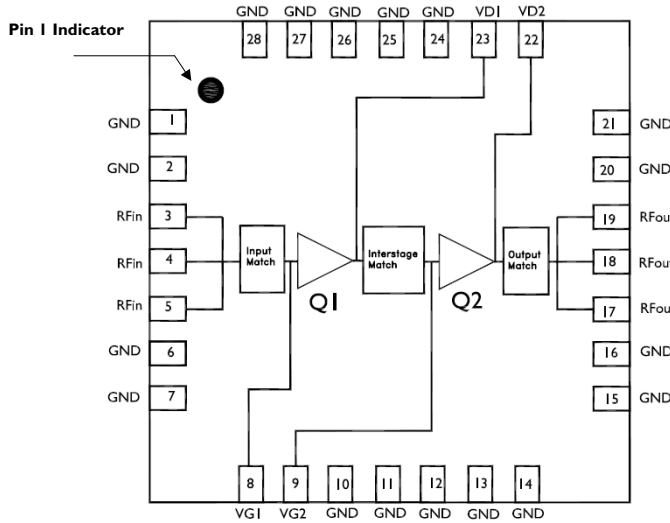

Pin-out Details

Pin #	Function	Description
3, 4, 5	RF IN	RF Input
8	VG1	Gate Voltage 1 st Stage (Negative)
9	VG2	Gate Voltage 2 nd Stage (Negative)
17, 18, 19	RF OUT	RF Output
23	VD1	Drain Voltage 1 st Stage (Positive)
22	VD2	Drain Voltage 2 nd Stage (Positive)
1, 2, 6, 7, 10, 11, 12, 13, 14, 15, 16, 20, 21, 24, 25, 26, 27, 28	GND	

Physical Dimensions

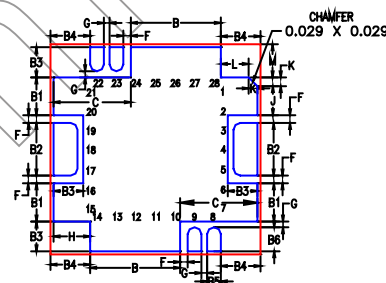
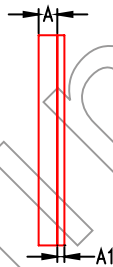
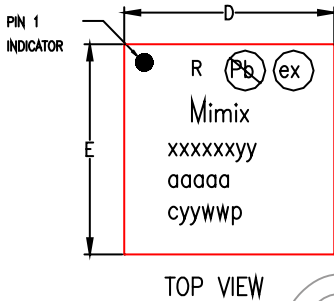

BOTTOM VIEW

MARKINGS:
PIN 1/BOX REV/Pb FREE SW
MIMIX CO. NAME
MIMIX PART/MODEL NO.
WAFER LOT NUMBER
DATE CODE/PLATING

RECOMMENDED SOLDER PAD PITCH AND DIMENSIONS
DIMENSIONS ARE IN MM [INCHES]

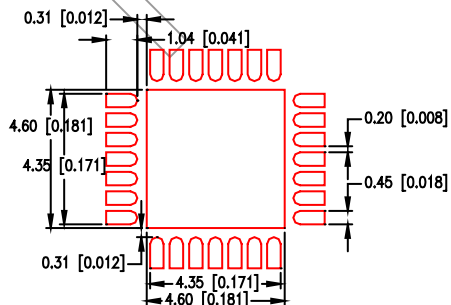

NOTE:
1. ALL DIMENSIONS ARE IN MM AND INCHES.

	MIN	TYP	MAX	MIN	TYP	MAX
A	0.61	0.66	0.71	0.021	0.026	0.031
A1	—	0.20	—	—	0.008	—
B	0.40	3.00	0.50	0.113	0.118	0.023
B1	1.21	1.26	1.31	0.045	0.050	0.055
B2	1.70	1.75	1.80	0.064	0.069	0.074
B3	0.94	0.99	1.04	0.034	0.039	0.044
B4	1.27	1.32	1.37	0.047	0.052	0.057
B5	0.41	0.46	0.51	0.013	0.018	0.023
B6	0.75	0.80	0.85	0.026	0.031	0.036
C	2.47	2.52	2.57	0.094	0.099	0.104
D	7.00 BSC			0.276		
E	7.00 BSC			0.276		
F	0.20	0.25	0.30	0.005	0.010	0.015
G	0.14	0.19	0.24	0.002	0.007	0.012
H	1.17	1.22	1.27	0.043	0.048	0.053
J	0.92	0.97	1.02	0.033	0.038	0.043
K	0.24	0.29	0.34	0.006	0.011	0.016
L	0.88	0.93	0.97	0.031	0.036	0.041
M	1.05	1.10	1.15	0.038	0.043	0.048

1. VIEWS ARE NOT TO SCALE: USE DIMENSIONS AND TABLE.

4.9-5.9 GHz 3W Power Amplifier Module

August 2009 - Rev 30-Aug-09

PI044-QL
RoHS

App Note [1] Biasing - The XP1044-QL requires power supply sequencing. Negative voltage supply (V_{gg}) needs to be turned on first and then positive voltage can be applied to the drain (V_{dd}). When turning off the device, the positive supply (V_{dd}) should be turned off first and then negative voltage (V_{gg}) can be removed.

The gate voltage is adjusted in order to set the drain current to the desired level. The gate voltage required to achieve a certain current can vary over temperature and from one device to another due to pinch-off voltage variation. Constant drain current can be achieved by implementing an active bias circuit which allows for temperature compensation and eliminates the effect of pinch off voltage variation.

The same current mirror circuit is implemented for each stage adding a total of 12 components at a cost of approximately \$0.29

Application Circuit Schematic

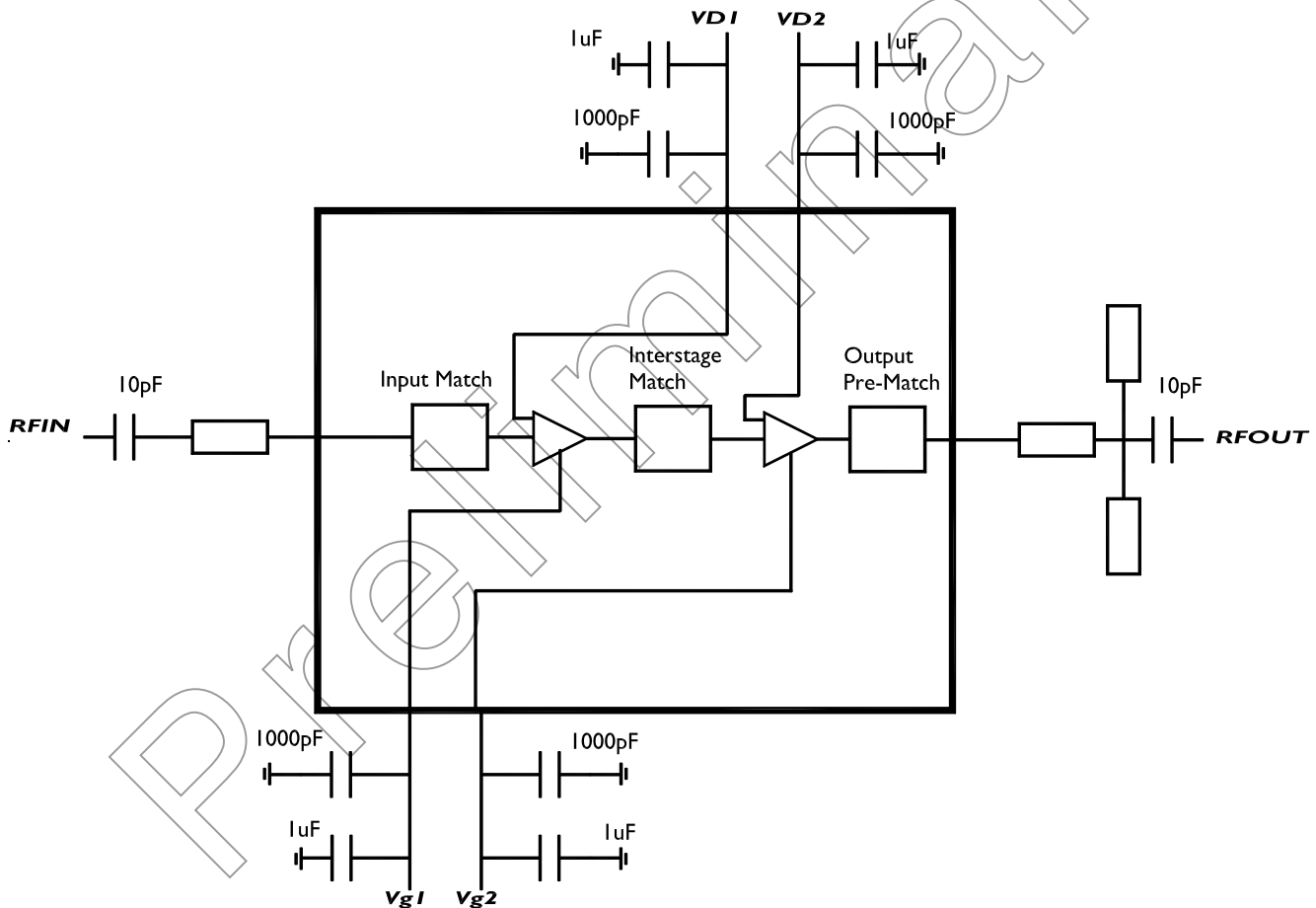

4.9-5.9 GHz 3W Power Amplifier Module

August 2009 - Rev 30-Aug-09

Handling and Assembly Information

CAUTION! - Mimix Broadband MMIC Products contain gallium arsenide (GaAs) which can be hazardous to the human body and the environment. For safety, observe the following procedures:

- Do not ingest.
- Do not alter the form of this product into a gas, powder, or liquid through burning, crushing, or chemical processing as these by-products are dangerous to the human body if inhaled, ingested, or swallowed.
- Observe government laws and company regulations when discarding this product. This product must be discarded in accordance with methods specified by applicable hazardous waste procedures.

Life Support Policy - Mimix Broadband's products are not authorized for use as critical components in life support devices or systems without the express written approval of the President and General Counsel of Mimix Broadband. As used herein: (1) Life support devices or systems are devices or systems which, (a) are intended for surgical implant into the body, or (b) support or sustain life, and whose failure to perform when properly used in accordance with instructions for use provided in the labeling, can be reasonably expected to result in a significant injury to the user. (2) A critical component is any component of a life support device or system whose failure to perform can be reasonably expected to cause the failure of the life support device or system, or to affect its safety or effectiveness.

Package Attachment - This packaged product from Mimix Broadband is provided as a rugged surface mount package compatible with high volume solder installation. Care should be taken not to apply heavy pressure to the top or base material to avoid package damage. Vacuum tools or other suitable pick and place equipment may be used to pick and place this part. Care should be taken to ensure that there are no voids or gaps in the solder connection so that good RF, DC and ground connections are maintained. Voids or gaps can eventually lead not only to RF performance degradation, but reduced reliability and life of the product due to thermal stress.

Mimix Lead-Free RoHS Compliant Program - Mimix has an active program in place to meet customer and governmental requirements for eliminating lead (Pb) and other environmentally hazardous materials from our products. All Mimix RoHS compliant components are form, fit and functional replacements for their non-RoHS equivalents. Lead plating of our RoHS compliant parts is 100% matte tin (Sn) over copper alloy and is backwards compatible with current standard SnPb low-temperature reflow processes as well as higher temperature (260°C reflow) "Pb Free" processes.

Ordering Information

Part Number	Description
XP1044-QL-0N00	Ni/Au plated RoHS compliant 7x7mm surface mount package in bulk quantity
XP1044-QL-EV1	Evaluation Board